

# SS SERIES

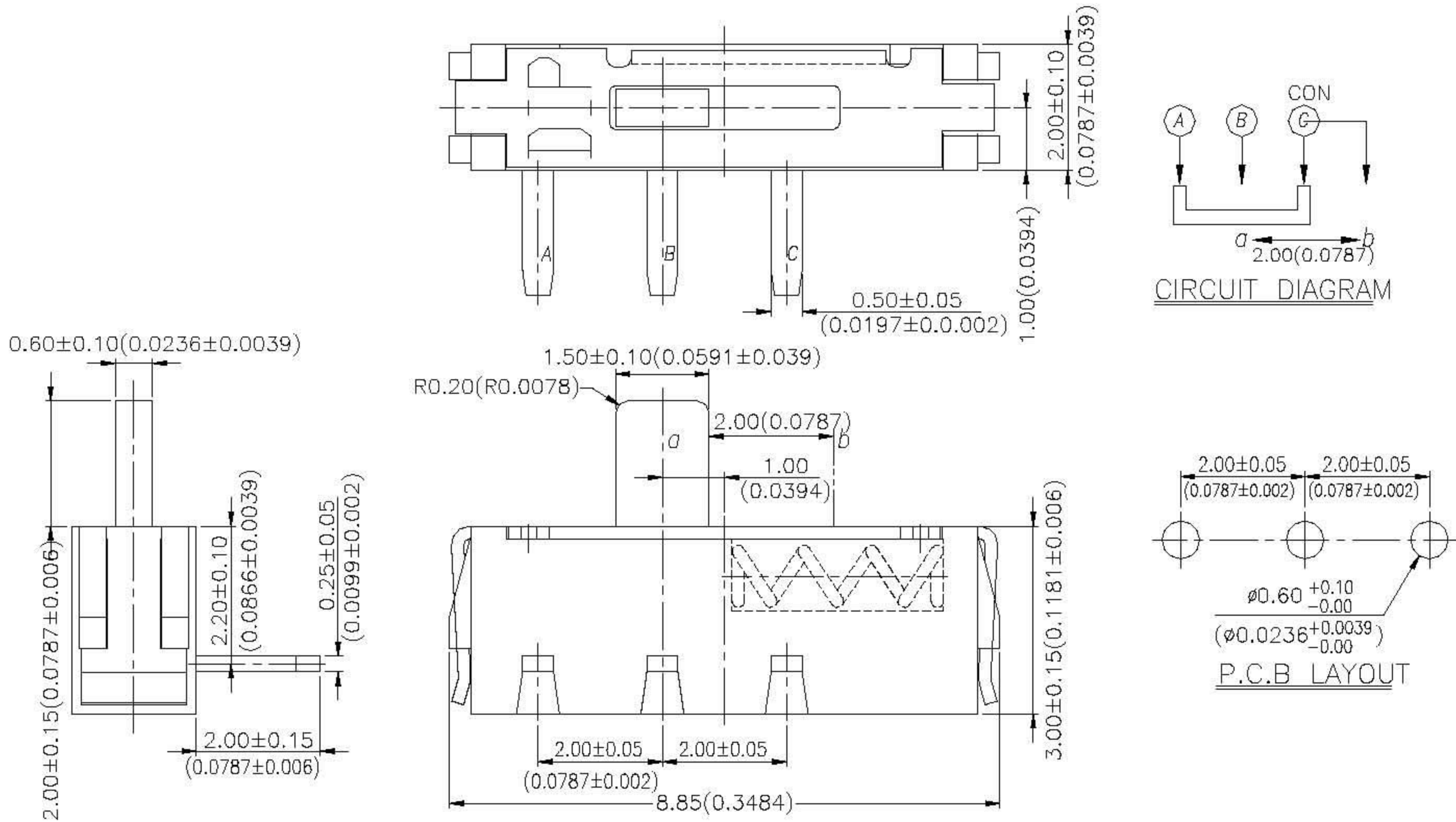

## DIMENSION

### SS3-HS



General Tolerance :  $\pm 0.2\text{mm}$

### SS3-CM

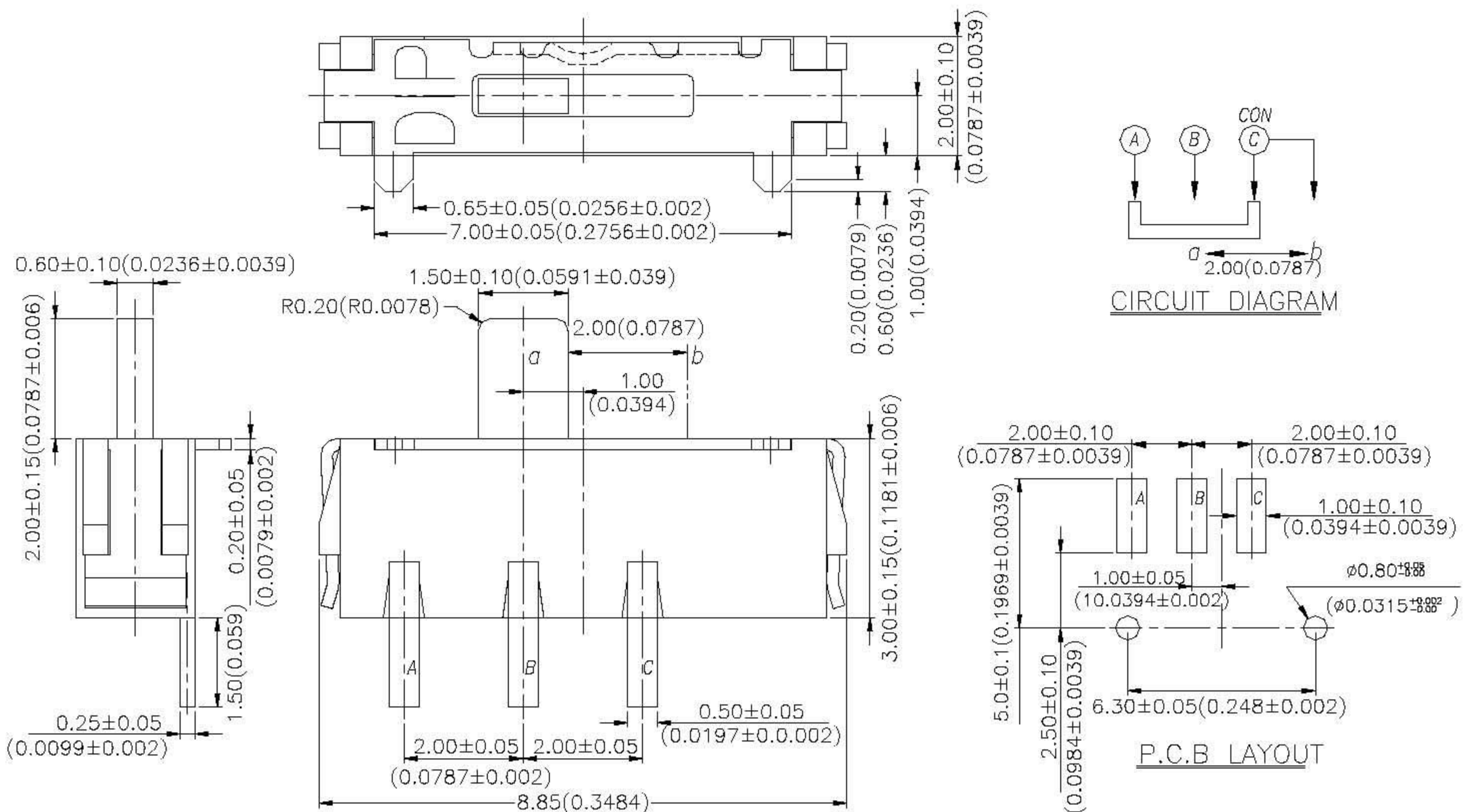

General Tolerance :  $\pm 0.2\text{mm}$

**SS4-CMS**

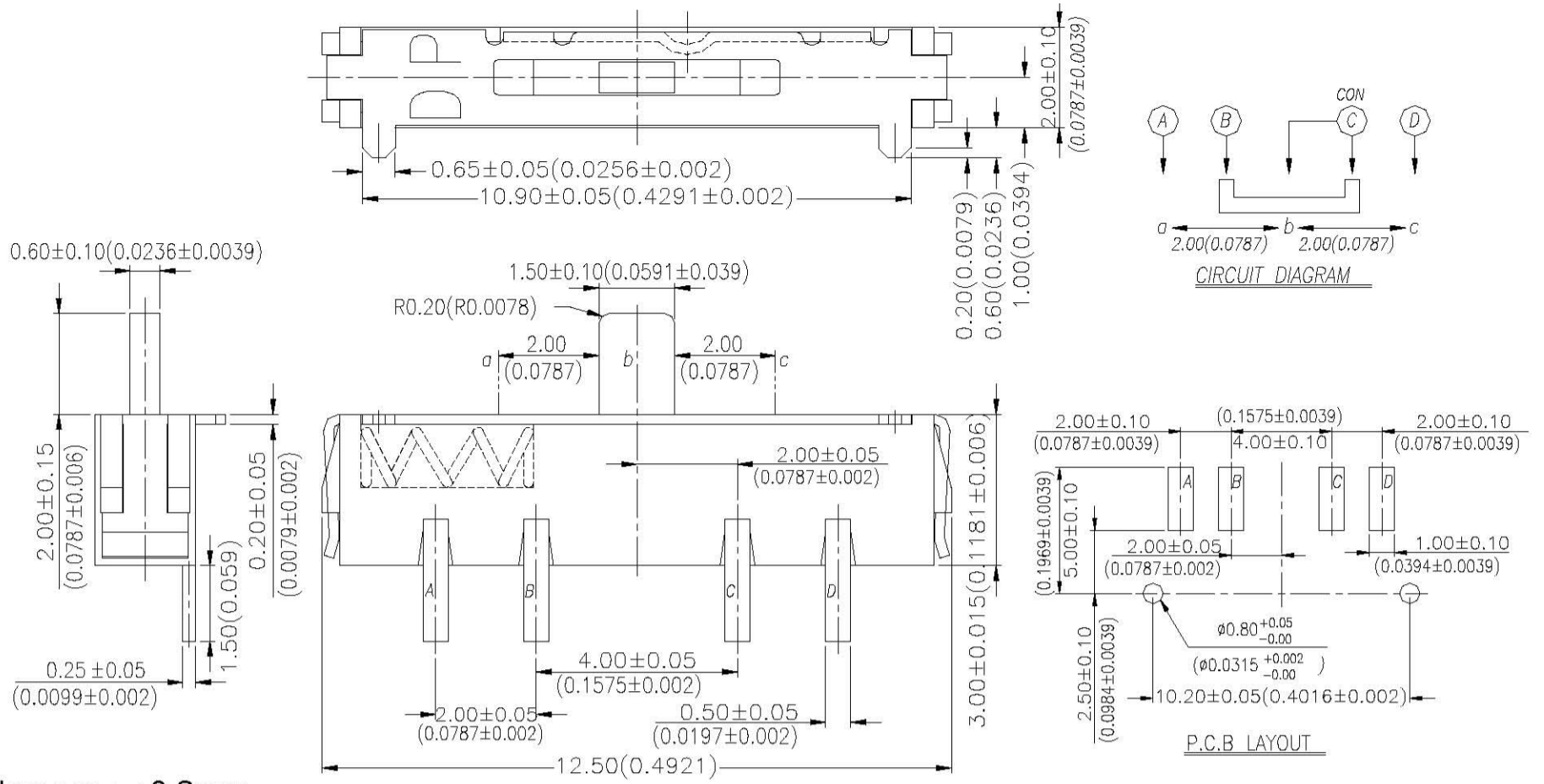

General Tolerance : ±0.2mm

**SS4-H**

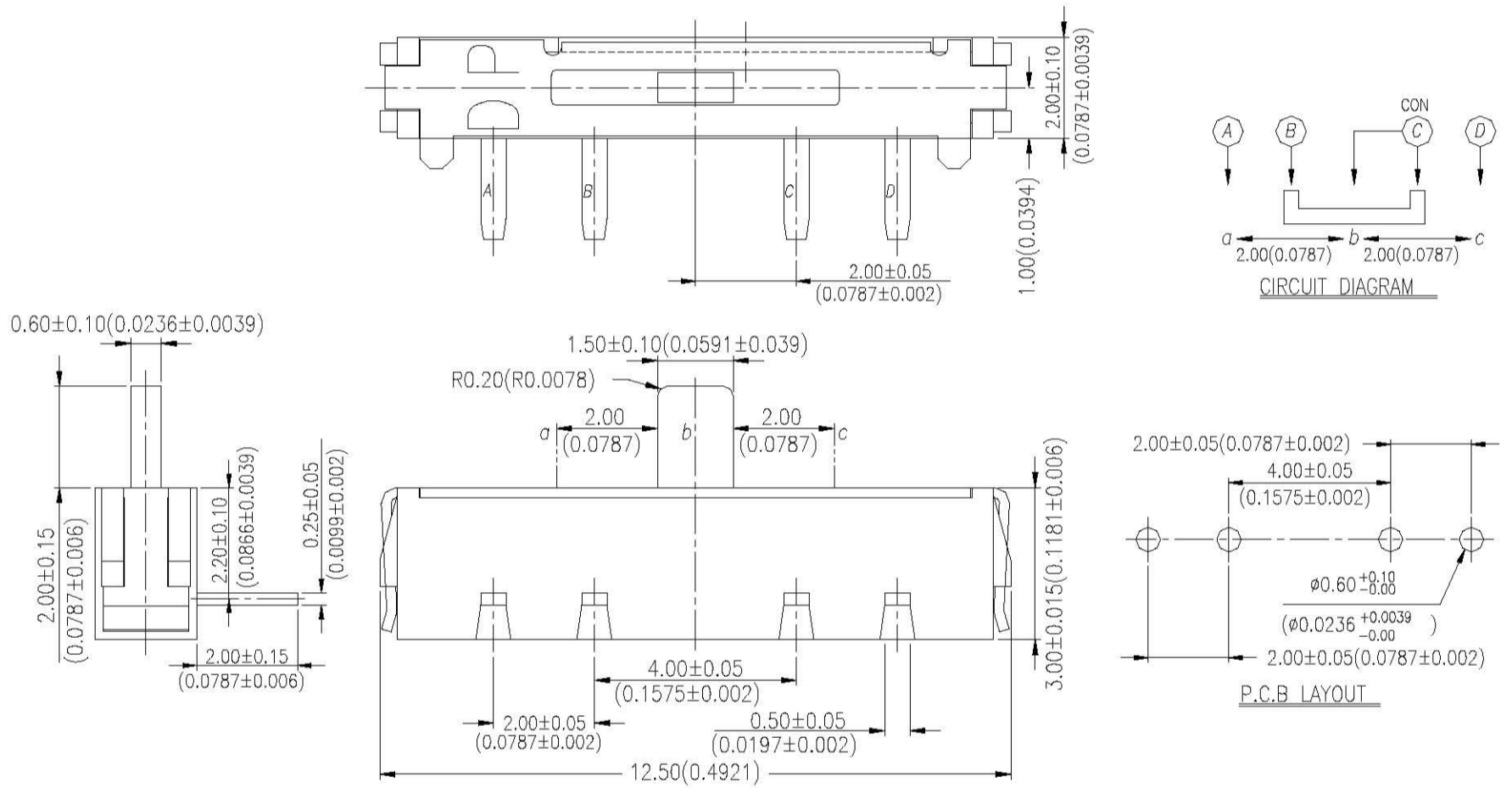

General Tolerance : ±0.2mm

**SS4-CHS2**

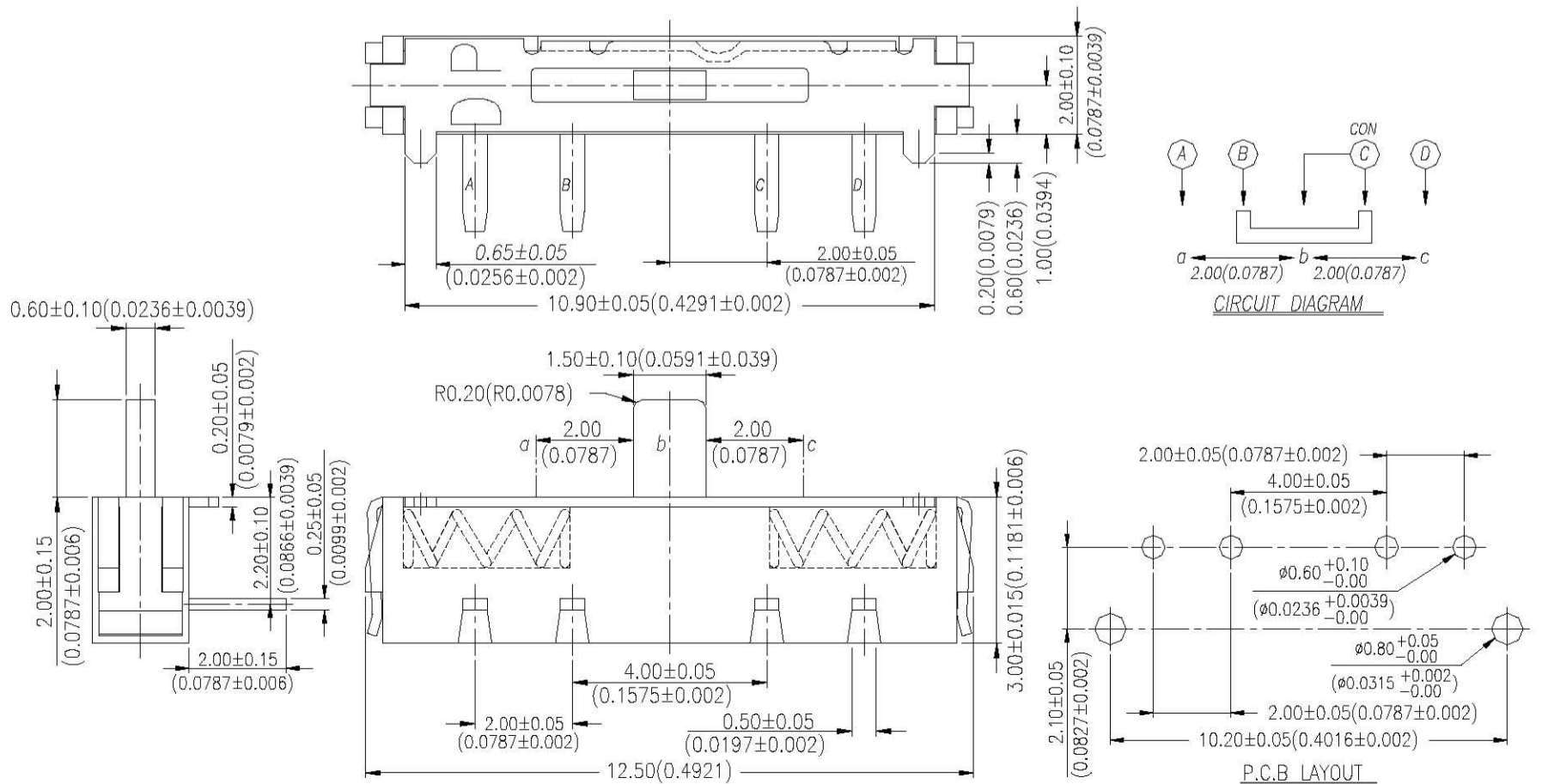

General Tolerance : ±0.2mm

## HOW TO ORDER

SS □ □ - □ □ □ □ □ □ □ □ - □ - □

### Package Style :

□ = Bag  
T/R = Tape & Reel <SS-M Only>  
B = Tube

### Soldering :

V = Lead Free Solderable

### Operation Force :

□ = 350g <3.43N>  
F = 150g <1.47N>

L = Long Terminals

① Terminals Size 3.2mm Of Slide Operation

② Terminals Size 2.7mm Of Vertical Actuation

C = Actuator in Right Side <SS3 Only>

2 = Double-Side Recoil <SS4 Only>

S = Single-Side Recoil

### Terminal Type :

H = Through Hole

M = SMT

C = With Post

P = Vertical Actuation <SS4 Only>

### Poles-Positions :

3 = 1P2T

4 = 1P3T

Slide Switch

## SPECIFICATION

### △MECHANICAL

Mechanical Life: 10,000 cycles

Operation Force: 350gf (Standard)

150gf (lighter operating force)

Operation Temp: -20°C to +70°C

Storage Temp: -40°C to +85°C

### △ELECTRICAL

Electrical Life: 10,000 cycles

Non-switching Rating: 100mA, 50VDC

Switching Rating: 25mA, 24 VDC

Contact Resistance: 100mΩ max.

Insulation Resistance: 100MΩ min. (500VDC)

Dielectric Strength: 500VAC/ 1minute

Circuit: 1P2T, 1P3T

## MATERIAL

△COVER: Stainless steel

△BASE: LCP High-Temp thermoplastic

Color: Black

△ACTUATOR: LCP thermoplastic

Color: Black

△CONTACT: Alloy copper

△TERMINAL: Brass C2680-H

## SOLDERING PROCESS

- △ HAND SOLDERING : Use a soldering iron of 30 watts, controlled at 350°C approximately 5 seconds while applying.
- △ WAVE SOLDERING : Recommended solder temperature at 500°F(260°C)max. 5 seconds for through Hole type.
- △ REFLOW SOLDERING : When applying reflow soldering, the peak temperature or the reflow oven should be set to 260°C max.

△ Temperature Profile :

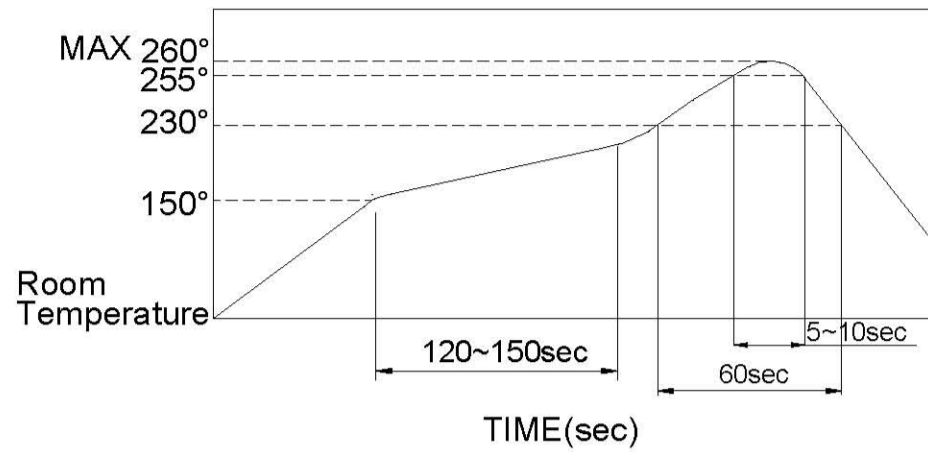

## PACKING

Part Number	Number Per Reel	Number Per Tube
SS3-H-B		53
SS3-HS-B		53
SS3-HSC-B		53
SS4-H-B		38
SS4-HS-B		38
SS4-HS2-B		38
SS3-CM-T/R	1900	
SS3-CMS-T/R	1900	
SS3-M-T/R	1900	
SS4-CM-T/R	1900	
SS4-CMS-T/R	1900	
SS4-CMS2-T/R	1900	
SS4-M-T/R	1900	
SS4-MS-T/R	1900	
SS4-CMS2-T/R	1900	
SS3-CMSC-T/R	1900	
SS3-MS-C-T/R	1900	

SS4 · 3 TUBE

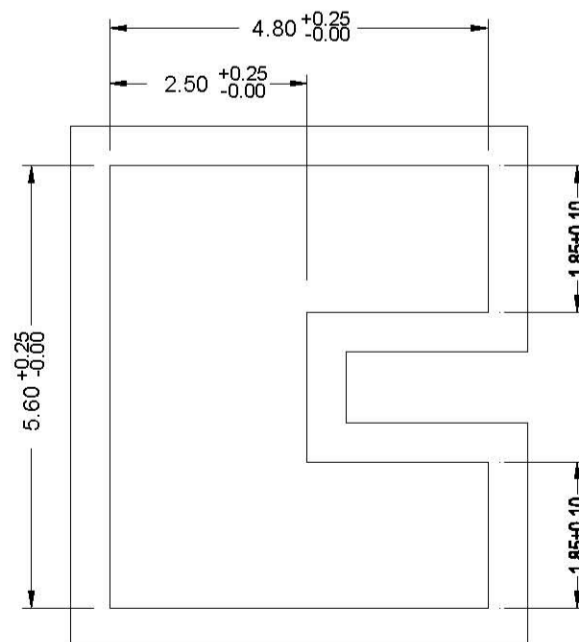

General Tolerance : ±0.2mm

SS3 REEL

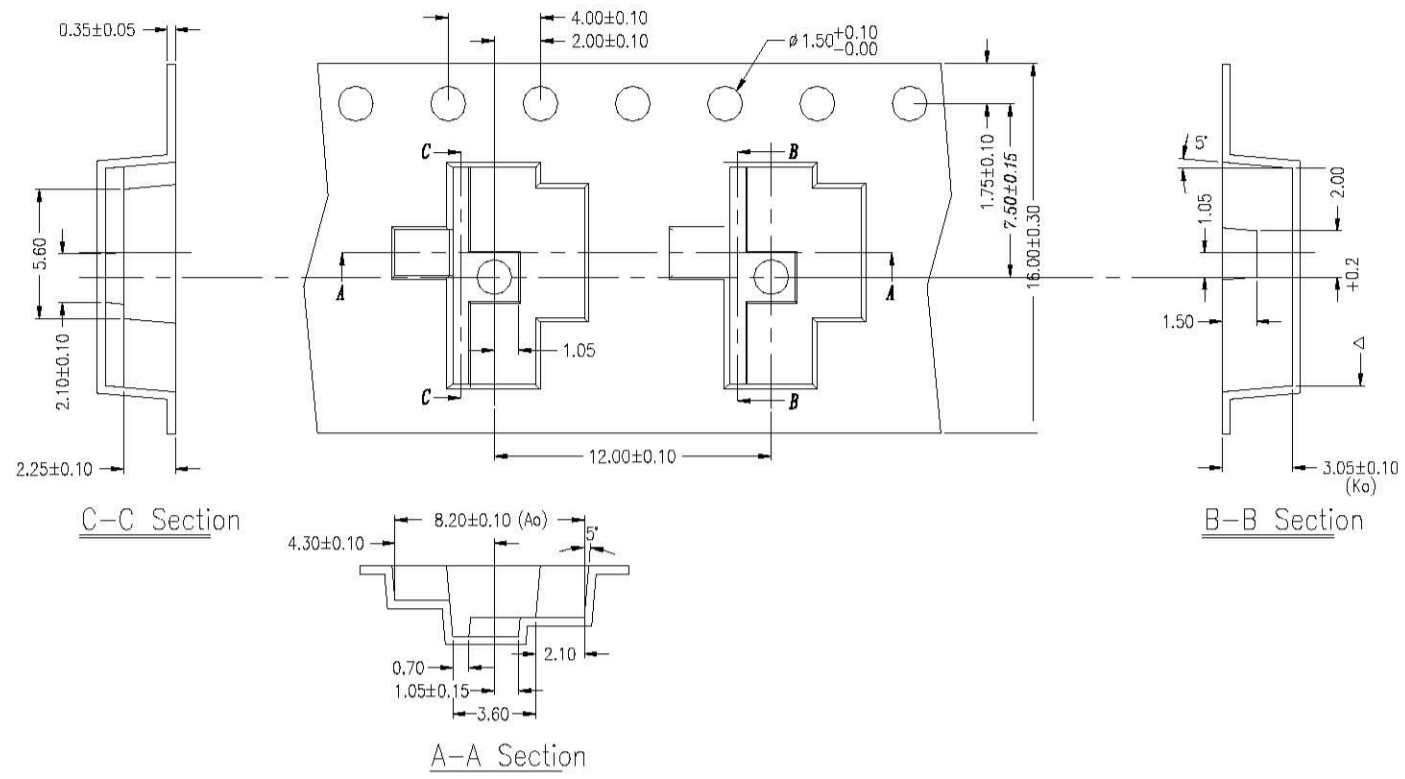

General Tolerance : ±0.1mm

SS4 REEL

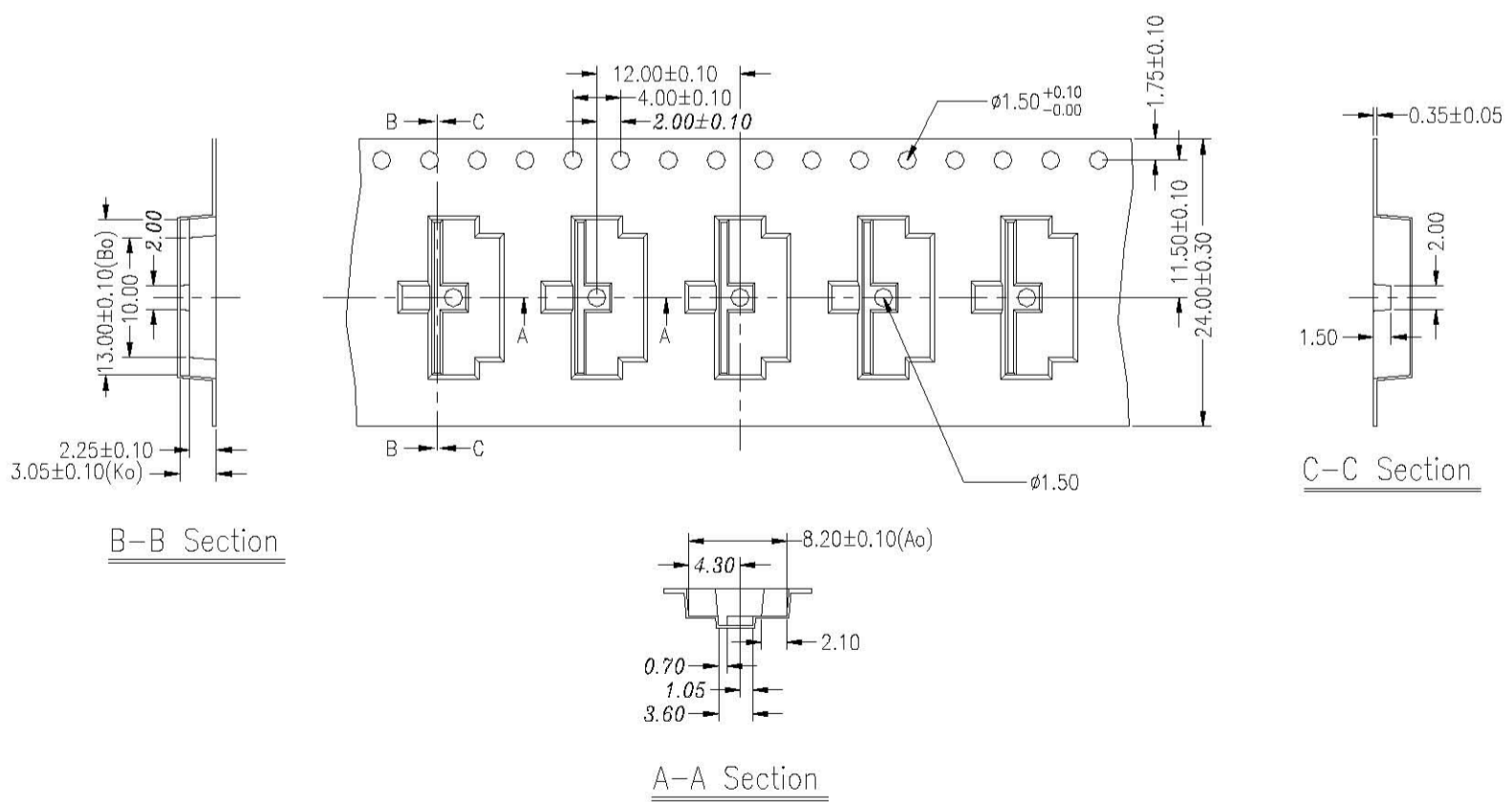

General Tolerance : ±0.1mm

SSC-M REEL

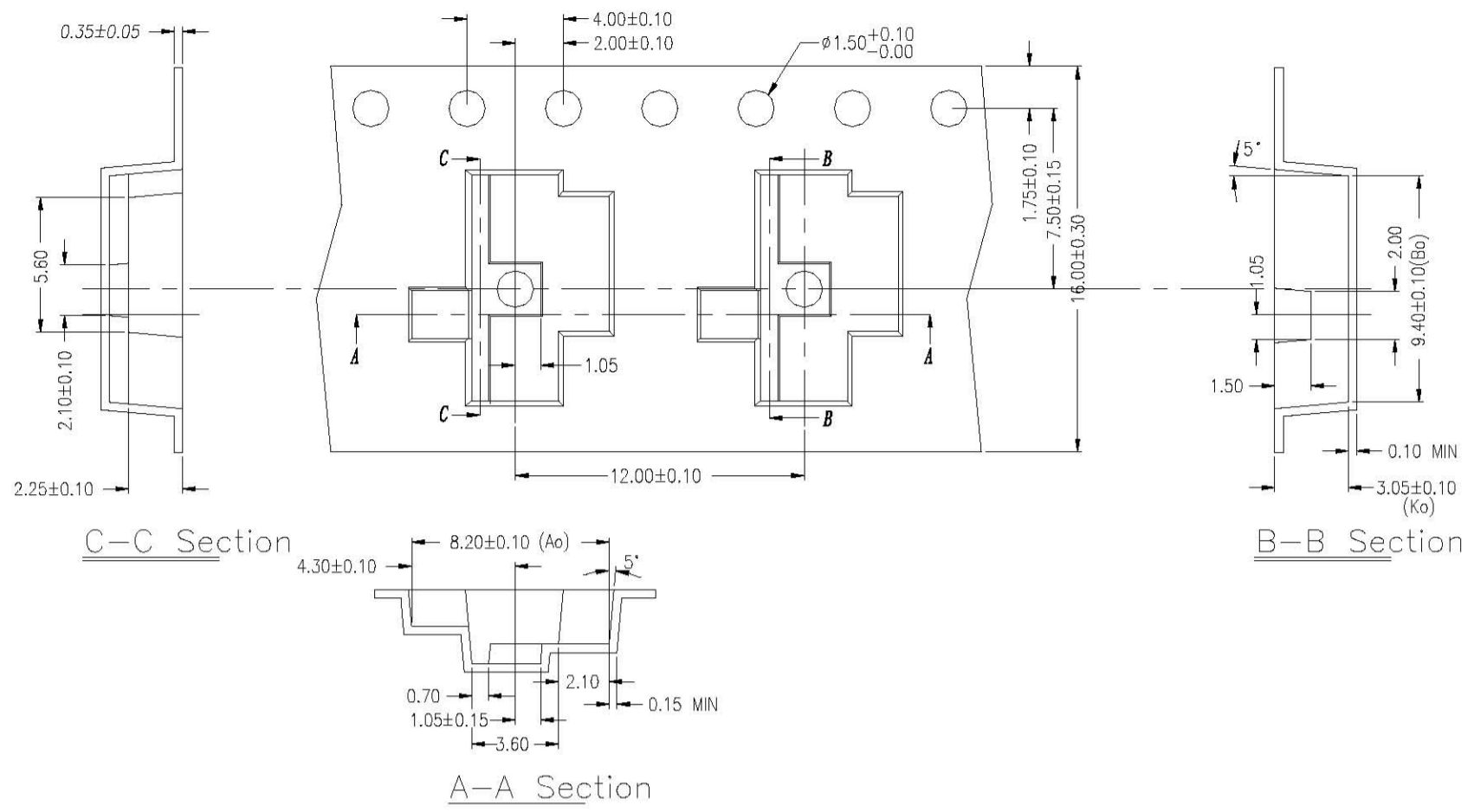

General Tolerance : ±0.1mm